

Diadem Manual Pdf

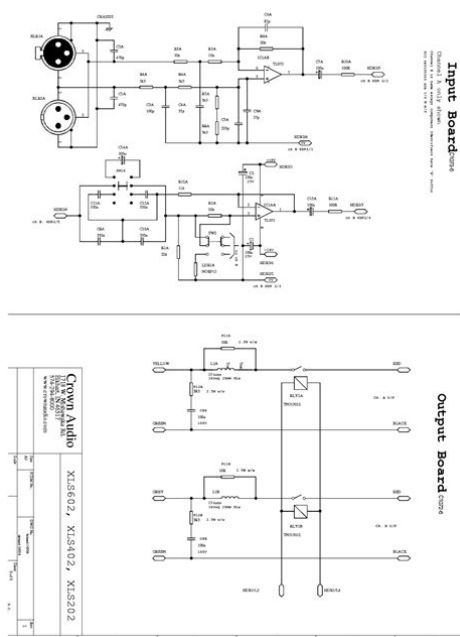

File Name: Diadem Manual Pdf.pdf

Size: 3229 KB

Type: PDF, ePub, eBook

Category: Book

Uploaded: 6 May 2019, 12:27 PM

Rating: 4.6/5 from 678 votes.

Status: AVAILABLE

Last checked: 19 Minutes ago!

In order to read or download Diadem Manual Pdf ebook, you need to create a FREE account.

[**Download Now!**](#)

eBook includes PDF, ePub and Kindle version

[Register a free 1 month Trial Account.](#)

[Download as many books as you like \(Personal use\)](#)

[Cancel the membership at any time if not satisfied.](#)

[Join Over 80000 Happy Readers](#)

Book Descriptions:

We have made it easy for you to find a PDF Ebooks without any digging. And by having access to our ebooks online or by storing it on your computer, you have convenient answers with Diadem Manual Pdf . To get started finding Diadem Manual Pdf , you are right to find our website which has a comprehensive collection of manuals listed.

Our library is the biggest of these that have literally hundreds of thousands of different products represented.



Book Descriptions:

Diadem Manual Pdf

Common tasks such as distinguishing and characterizing neuron phenotypes, modeling projection and potential connectivity patterns, and simulating the electrophysiological behavior of single neurons and neuronal networks all depend on accurate knowledge of 3D neuronal morphology. In fact, such tasks often require the morphology to be explicitly and quantitatively described as opposed to simply illustrated by an image stack 1. Therefore a critical first step in many studies is the digital reconstruction of the 3D morphology of neurons from image stacks. To this day, manual tracing is still the prevailing method even for 3D reconstruction 2. However, manual approaches are prohibitively expensive for analyzing image data approaching the scale of terabytes and thousands of image stacks, let alone mining higherorder patterns in these data. The longstanding need to automate the laborious and subjective manual analysis of lightmicroscopic and other types of microscopic images has motivated a large number of bioimage informatics efforts 3. The recent advance in imaging throughput, combined with the desire for largescale computational modeling, has added a sense of urgency to this need. In 2010 a worldwide neuron reconstruction contest named DIADEM short for “digital reconstruction of axonal and dendritic morphology” was organized by several major institutions as a way to stimulate progress and attract new computational researchers to join the technology development community 4. The goal of DIADEM was to develop algorithms capable of automatically converting stacks of images visualizing the treelike shape of neuronal axons and dendrites into faithful 3D digital reconstructions. The contest succeeded in stimulating a burst of progress. However, none of the algorithms presented at the finishing stage of DIADEM reached the originally projected goal of a 20fold speedup in the reconstruction process compared to manual reconstruction 5. <http://www.savol-rus.ru/userfiles/breville-br2-manual.xml>

- **diadem manual pdf, diadem manual pdf, diadem manual pdf download, diadem manual pdf free, diadem manual pdf converter, diadem manual pdf online.**

One practical limitation of DIADEM was that the reconstruction methods were implemented in different languages, ran on different platforms, and followed different protocols to load image data and export reconstructions. This hampered a direct comparison of the methods in terms of computational efficiency and has ever since been a stumbling block to further extend the experiment to bigdata, highthroughput applications. In addition, several relatively successful methods recently used in various neuroinformatics projects were introduced 6 or continued to be developed 7 after the DIADEM contest. Current reconstruction techniques, both manual and automated, show tremendous variability in the attributes and completeness of the resulting morphology 8. Yet, building a large library of high quality 3D neuron morphologies is essential to comprehensively cataloging the types of cells in a nervous system. Furthermore, enabling comparisons of neuron morphologies across species will provide additional sources of insight into neural function. It would be beneficial for neuron reconstruction related research and applications to aggregate and consolidate the collective progress on automated neuron tracing in a practically useful product for neuroscience applications. One strategy to overcome the difficulties in dealing with different tracing protocols, data formats, usability, and reproducibility, is to port the available methods to a common, versatile software platform. This allows the methods to be benchtested against very largescale neuron datasets for effective validation. The BigNeuron project has been formally launched in March 2015 to achieve such goals 9. This project aims to gather a worldwide community to define and advance the stateoftheart of single neuron reconstruction by benchtesting as many automated neuron reconstruction methods as possible against as many neuron datasets as possible following

standardized data protocols and evaluation

methods.<http://gorod-r.com/userfiles/breville-br9-breadmaker-manual.xml>

BigNeuron will durably benefit the neuroscience community by establishing a Big Data resource and a set of standardized novel tools for neuron morphologies. To make BigNeuron a success, tangible goals and feasible approaches have to be developed. While the vision for BigNeuron is to continue for a long time through multiple phases, the first phase will last about a year and a half. The goal of this first phase is to establish the basic infrastructure and release useful data, tools, and analyses. A series of events are being organized for 2015. The kickoff algorithmimporting hackathon was held in Beijing, China in March 2015, with more than 20 attendees from various research groups from Asia, Australia, and America. Followup hackathons and workshops will be held at several other locations in Europe and USA. The benchtesting will start in the summer of 2015, followed by data analysis open to the world community. The project welcomes and encourages the participation of any individuals and organizations. Subsequent phases may add important layers of complexity such as timelapse, multichannel, and multineuron data. In the long run, BigNeuron may also enable a robust cloudbased automated service, where researchers could upload an image stack and receive back a digital morphological tracing. To advance the neuron reconstruction field, collaborative community projects such as BigNeuron can powerfully complement the competitive spirit of previous initiatives such as DIADEM. The suitability of various neuron reconstruction methods for specific neuron image datasets can still be quantified and ranked from the forthcoming BigNeuron results. However, the synergy of many research groups across the globe may provide a refreshing perspective on how various reconstruction methods and results might be integrated. Without a doubt, benchtesting many reconstruction methods against many neuron image datasets will produce very largescale reconstruction databases.

Consensus reconstructions created from all variants generated with each algorithm will also be deposited in NeuroMorpho.Org ensuring availability in both the de facto standard SWC and NeuroML formats as well as potentially other databases. Such Big Data will not only benefit method developers and image contributors, but also provide valuable new data resources for computational modelers and data analysts. References 1. Parekh R, Ascoli GA. The importance of metadata to assess information content in digital reconstructions of neuronal morphology. All rights reserved. Important Information Warranty The media on which you receive National Instruments software are warranted not to fail to execute programming instructions, due to defects in materials and workmanship, for a period of 90 days from date of shipment, as evidenced by receipts or other documentation. National Instruments will, at its option, repair or replace software media that do not execute programming instructions if National Instruments receives notice of such defects during the warranty period. National Instruments does not warrant that the operation of the software shall be uninterrupted or error free. A Return Material Authorization RMA number must be obtained from the factory and clearly marked on the outside of the package before any equipment will be accepted for warranty work. National Instruments will pay the shipping costs of returning to the owner parts which are covered by warranty. National Instruments believes that the information in this document is accurate. The document has been carefully reviewed for technical accuracy. In the event that technical or typographical errors exist, National Instruments reserves the right to make changes to subsequent editions of this document without prior notice to holders of this edition. The reader should consult National Instruments if errors are suspected.

<http://www.raumboerse-luzern.ch/mieten/bosch-nexxt-dryer-service-manual>

In no event shall National Instruments be liable for any damages arising out of or related to this document or the information contained in it. Any action against National Instruments must be brought within one year after the cause of action accrues. National Instruments shall not be liable for any delay in performance due to causes beyond its reasonable control. The warranty provided

herein does not cover damages, defects, malfunctions, or service failures caused by owner's failure to follow the National Instruments installation, operation, or maintenance instructions; owner's modification of the product; owner's abuse, misuse, or negligent acts; and power failure or surges, fire, flood, accident, actions of third parties, or other events outside reasonable control. Copyright Under the copyright laws, this publication may not be reproduced or transmitted in any form, electronic or mechanical, including photocopying, recording, storing in an information retrieval system, or translating, in whole or in part, without the prior written consent of National Instruments Corporation. National Instruments respects the intellectual property of others, and we ask our users to do the same. NI software is protected by copyright and other intellectual property laws. Where NI software may be used to reproduce software or other materials belonging to others, you may use NI software only to reproduce materials that you may reproduce in accordance with the terms of any applicable license or other legal restriction. Trademarks DIAdem, LabVIEW, National Instruments, NI, ni.com, the National Instruments corporate logo, and the Eagle logo are trademarks of National Instruments Corporation. Other product and company names mentioned herein are trademarks or trade names of their respective companies.

<http://intrasservices.com/images/Data-Protector-Express-6-Manual.pdf>

Members of the National Instruments Alliance Partner Program are business entities independent from National Instruments and have no agency, partnership, or jointventure relationship with National Instruments. Each chapter describes a DIAdem panel. This manual contains exercises for finding, analyzing, and presenting data, and for automating functions to process your data. The exercises do not take long, and they make it easier for you to get started with DIAdem. Each chapter concludes with a summary of the main points. This icon denotes a tip, which alerts you to advisory information. This icon denotes a note, which alerts you to important information. Parameters are also in bold type. This font is also used for the proper names of disk drives, paths, folders, programs, subprograms, subroutines, device names, functions, operations, commands, variables, controls, events, methods, filenames and extensions, and code excerpts. In a uniform environment, DIAdem offers a unique combination of tools that are tailored to the requirements of technicians, engineers, and scientists. You can adjust all the tools to your tasks and automate them in scripts which drastically reduce the evaluation time. The DIAdem DataFinder enables you to find test data quickly and intuitively, and to identify correlations within the data. To use the DataFinder you do not require a database or support from the IT department because the DataFinder is ready for use directly after installation. Working with DIAdem DIAdem groups related functions in panels. Use the panel bar that is on the left of the DIAdem screen to switch panels. Use the DataFinder to search for data on your computer and in the network, and to navigate through the found data files and databases. You synchronize videos or the map display of a test drive with data. You can apply predefined standard mathematical functions, including basic mathematics, curve fitting, signal analysis, and statistics.

<http://www.isovca.com/images/Data-Protector-Installation-Manual.pdf>

The dialog boxes for these standard functions guide you through the calculation so you do not have to enter a formula. You select the input data and the settings. In 2D and 3D axis systems you display your data as curves, as bar diagrams, and as surfaces. In 2D and 3D tables you list channel contents. Scripts, which you can record interactively, use the functions of all DIAdem panels. You can add program structures and dialog boxes to scripts in the integrated script editor. Chapter 1 Introduction to DIAdem When you select a panel, DIAdem changes the user interface so that you can quickly find the functions you want. Each DIAdem panel has its own group bar to the right of the panel bar as shown in Figure 11. Open a group bar, click a function group, and select a function. The workspace also changes with the DIAdem panel and displays a folder hierarchy or a worksheet. The introduction screen includes video tutorials and examples that show you how to work with DIAdem. The information on DIAdem contains tips for newcomers and for advanced users and leads you to

related information on the internet. The DIAdem panels contain tutorials in the tutorials function group that explain the respective panel. Use the Example Gallery or the ExampleFinder to load and execute examples and to use these examples as templates for your own applications. The table of contents of the ExampleFinder contains procedures which are stepbystep instructions for the solution of certain tasks. Use the DataFinder to search for data on your computer and in the network, and to navigate through the found data files and databases. You load the data into the Data Portal so that all DIAdem panels can work with the data, which is organized in channels. Mining Data Use the Quick Search to search for a term if you do not know whether the property belongs to a file, a group, or a channel. Use the Advanced Search to combine several search conditions and to specify which properties you are searching for.

Executing a Quick Search To find data with a Quick Search, complete the following steps. 1. Select DIAdem NAVIGATOR. The file browser in the NAVIGATOR panel offers external data in a tree structure. 2. Enter Weather in the input area, to find all the data sets that contain the term Weather. 3. Click Search. Chapter 2 Finding Data In the quick search DIAdem does not distinguish whether the data set contains the term as the name or the property of a file, of a channel group, or of a channel. DIAdem lists the names of all the groups found. c. Doubleclick the group name Weather. Note If the list does not contain the term Weather, DIAdem has not been able to index all example files yet. Define another search condition in the second row to specify the search more accurately. 3. Click File in the second row of the Level column and select Channel. a. Click in the Property column of the second row and select Name. b. Click the button with the three dots at the end of the second row. DIAdem lists the names of all the channels found, as shown in Figure 22. c. Doubleclick the channel name Precipitation. DIAdem switches from the search results to the file browser and displays the Data1.tdm file with the TDM file symbol in the tree structure. If the file browser knows the file format, it displays the respective file symbol before the file. DIAdem lists all the channel groups and channels that are contained in a file, in a tree structure. You can browse down to the channel level in the files if the file format supports browsing. You can find further information on the selected file, channel group, or channel in the Properties window below the File Browser as shown in Figure 24. If you select a channel, the channel preview to the right of the properties display shows the channel data as a curve. Figure 24. Browsing the Found Files in the File Browser Loading and Managing Data If you want to work with the data you have found, you must load the data into the Data Portal.

The Data Portal displays the Weather channel group with all the channels, as shown in Figure 25. If you select a channel, the channel preview of the Data Portal displays the channel data as a curve. Figure 25. Loading Data from the File Browser to the Data Portal Note If you modify data in the Data Portal, DIAdem does not save the changes automatically. The changes are executed only in the memory and not in the data file from which you loaded the data. This enables you to experiment with data without modifying the original data. It also includes additional information. DataFinder In the search input area of the DataFinder you enter search conditions to find your data. You also can drag and drop properties from the properties display of the Data Portal or of the file browser into the search input area. In the logical operations line you connect the search conditions with AND and OR and use parentheses to specify queries more precisely. DIAdem lists the files found in the search areas on the Search Results tab. DataFinder Server Edition The DataFinder Server Edition indexes data files in the network and enables up to 25 DIAdem users to access common search areas simultaneously. You can enable security settings and use archiving systems. Search Areas Search areas are folders of the file system, which the DataFinder indexes. File Browser The File Browser displays the files of the search areas in a tree structure. Rightclick the empty space of the file browser to open the context menu and hide or show the folders of the local file system in a separate tree. Internal Data in the Data Portal DIAdem manages internal data in the Data Portal, which is visible in all panels. In all DIAdem panels you work with the channels of the internal data and their

descriptive information. DIAdem saves result data in the Data Portal. You can display and edit the channel contents in DIAdem VIEW.

Tip You do not need the **or** keys to select several channels in the Data Portal; just click the symbols next to the channel names. DIAdem displays a cursor with a plus sign. Channel Groups Channel groups contain channels and descriptive properties of the channel groups. Use different channel groups to organize your data. You can define a channel group as a default group, for example, to automatically group together all the calculation results from DIAdem ANALYSIS. DIAdem distinguishes numeric channels, waveform channels, time channels, and text channels. Numeric channels contain data series, waveform channels contain data series and the associated xchannel as a generation instruction, time channels contain time data series, and text channels contain text. Properties Properties are information about the data, which DIAdem saves with the data series in a TDM file. The data set properties contain the name of the author and the storage date, the channel group properties contain the name of the measurement and comments, and the channel properties contain the data type and the channel unit. In addition to the standard properties, you can create your own custom properties for the data set, the channel group, and the channel. DIAdem displays the properties in the properties displays of the file browser and of the Data Portal. Units Catalog The channel unit is a special channel property because you can organize the channel units in the units catalog. Use the units catalog to assign a physical quantity and a unit to measurement values, for example, the quantity speed and the unit kilometers per hour. You synchronize videos or the map display of a test drive with data. You project data onto 3D models or map 3D data in twodimensional contour areas. Viewing Curves To view the loaded data set in an axis system, complete the following steps. Note If you have not completed the exercise from the previous chapter, load the data set Data1.tdm located in the DIAdem Data folder.

You find this folder in the DIAdem NAVIGATOR file browser in the search area National Instruments. 1. Select DIAdem VIEW. 2. Click New Layout. 3. Click Regular Worksheet Partitions on the group bar. 4. Click Two Areas in this function group. Note Each panel has its own group bar on the left side. When you click a button on the group bar, DIAdem opens the function group where you can select a function. The cursor changes its color and displays a plus sign. 7. Drag and drop the three channels selected in the Data Portal into the upper worksheet area. 8. Select 2D Axis System in the selection dialog box. DIAdem displays the axis system as shown in Figure 31. Figure 31. Viewing Temperature Data as Curves Note If you select several numeric channels in the Data Portal and drop the channels onto an axis system, DIAdem assigns the first channel you select to the xaxis. For a closeup view of curves, complete the following steps. 1. Click Band Zoom on the axis system toolbar. 2. Click the axis system and drag open the band to specify the width of the curve section. 3. Click Move on the axis system toolbar and move the curves to the section that you want to magnify. 4. Click Zoom In on the axis system toolbar to increase the zoom in the selected section. 5. Click Zoom Off to return from the zoomed area to the complete curve. 6. Click Move again to disable the move mode and to reactivate the cursor. Editing Curves In DIAdem VIEW you can measure curves, and copy, delete, and interpolate curve sections. Use the curve cursor, the maximum values cursor, or the minimum values cursor on the DIAdem VIEW toolbar to measure a curve. To edit curve sections use the flag functions on the axis system toolbar. DIAdem displays the xvalues and the yvalues of the curve points in a tooltip next to the crosshair cursor that follows the cursor. 3. Click a checkbox on the right side of the axis system to select a different curve as the leading curve.

DIAdem displays the coordinates of the new leading curve in the tooltip. Copying Curve Sections To select a curve section and to copy the data of the curve section into the Data Portal, complete the following steps. 1. Click Band Cursor on the toolbar. 2. Click the axis system at 3.04 and drag open the band cursor up to 12.03. Click between the two lines to move the band cursor along the curves. Move the cursor lines to specify the width of the band cursor. 3. Click Set Flags on the axis system

toolbar to mark the points of the leading curve in the selected time segment. In the Data Portal, DIAdem creates a time channel and a numeric channel with the values of the copied curve section. 5. Drag and drop the new channels into the bottom workspace. 6. Select 2D Axis System. You can enter or generate new data manually. To edit values in a channel table and to generate new values complete the following steps. 1. Click Assigned Worksheet Partitions on the group bar. 2. Click Channel Table in this function group. It also includes additional information. Layouts A layout can contain several worksheets. DIAdem saves layouts separately from the channels. You can reuse the layout as a template for data sets with a similar structure. Areas Partition worksheets into areas to insert axis systems, channel tables, videos, 3D models, contours, maps, dialog boxes, text, and images. You can move the separating bars to resize any area in a worksheet. Use the Assigned Worksheet Partitions function group to add new worksheets with predefined areas to a layout. Axis Systems In axis systems you display data as curves, as spikes, or as stair curves. To insert data into an axis system, drag and drop channels from the Data Portal into an axis system. Use the band cursor and the frame cursor to zoom curve sections. You open the legend on the right side of an axis system. Graphics Cursors DIAdem VIEW offers various graphics cursors for evaluating curves in axis systems.

The free cursor moves freely in the axis system and the curve cursor follows the curve from curve point to curve point. Other graphics cursors determine the maximum values and the minimum values of a curve. If an axis system contains several curves, the graphics cursor follows the leading curve that you specify with the checkboxes in the legend. DIAdem synchronizes all the cursors of a worksheet with each other and with videos and 3D models. Flags Use the band cursor and the frame cursor to mark curve sections with flags, to delete, to copy, or to recalculate the marked curve points. Channel Tables In channel tables you view the individual values of the channels, edit the values of all channel types, and add new values or channels. In the display properties of a channel table you can specify whether a channel table only displays the channels that were dragged and dropped into the table or whether the channel table automatically displays all channels of a group or of the Data Portal. Videos In video areas you show videos. If you display the associated measured values as curves in an axis system, you can move a graphics cursor along the curves to display the video frame associated with each measurement value. For example, you display temperatures as color shading on a climate dummy, and you display strain on bridge elements as deformation. To do so, you insert the 3D model of the test object and connect each data channel with the respective model point. For model points with no sensor, DIAdem interpolates the values from the data of neighboring model points. Contours In contour areas you display 3D data twodimensionally by displaying the third dimension of the data as a color value and with isolines. You can use a contour display, for example, to display and to analyze characteristic diagrams. If you move the graphics cursor over a contour, DIAdem displays the associated isolines dynamically.

You can save the data of every associated isoline and also the xparallel and yparallel intersection in the Data Portal. Maps In map areas you display geographic data in map sections. For example you can follow the route of a test drive when you move the graphics cursor in an axis system along the data such as consumption, RPM, and torque collected during the test drive. To do so enter the recorded longitude and latitude and, for example, the time channel for the synchronization. Dialog Boxes In dialog boxes you enter values, check settings, or start functions to change the displays in other areas of the layout during the analysis. You can apply predefined standard mathematical functions, including basic mathematics, curve fitting, signal analysis, and statistics. The dialog boxes for these standard functions guide you through the calculation so you do not have to enter a formula. You select only the input data and the settings. Use the DIAdem Calculator to define and calculate your own formulas. Using Standard Mathematical Functions DIAdem has extensive libraries of standard mathematical functions in several function groups in DIAdem ANALYSIS. The results of the calculations are displayed in new channels in the Data Portal. Note If you have not completed the

exercise from the previous chapter, load the data set Data2.tdm located in the DIAdem Data folder. You find this folder in the DIAdem NAVIGATOR file browser in the search area National Instruments. Enable the checkbox Set default group. 4. Click OK. DIAdem displays the name of the default group in bold type in the Data Portal. This notation means the Precipitation sum channel is in the first channel group. 5. Click OK. 6. Enter 213 as the Rows. Tip To check which rows the precipitation for 2003 is in, switch to DIAdem VIEW and load the channels Month and Precipitation sum into a channel table. Calculating with the Units Catalog The DIAdem units catalog organizes physical quantities and the associated units.

Use the units catalog to convert channels into other units. Note You also can convert channel data to a different unit in the Data Portal. Calculating Formulas with the Calculator Use the DIAdem Calculator to calculate your own mathematical formulas. In the Calculator you calculate with channels, variables, and values you enter. DIAdem stores the results in channels or variables. To calculate the difference between the monthly maximum temperatures and the average temperatures, complete the following steps. 1. Click the Calculator on the toolbar. 2. Enter the following formula in the Calculator entry field. It also includes additional information. Mathematical Functions DIAdem ANALYSIS offers a variety of standard functions for analyzing your data. You assign input channels to standard functions, set parameters, and execute the calculation. Click OK to execute a calculation once and to close the dialog box. Click Calculate to execute several calculations with the same standard function. Result Channels DIAdem ANALYSIS saves calculation results in new channels. This enables you to calculate new data without overwriting the existing channels. In most dialog boxes of the standard functions you can select Store result in original channel to overwrite the existing channels. Default Group DIAdem stores the result channels of a calculation in the default group in the Data Portal. Define in the context menu a different group as the default group. DIAdem displays the group name of the default group in bold type. Calculator Use the Calculator to specify your own formulas for analyzing data. The Calculator has functions that range from simple arithmetic functions to advanced scientific and engineering functions. Use the Calculator to calculate channels, variables, and single values. DIAdem stores the results in channels or variables. Units If you assign units from the units catalog to the original channels, DIAdem automatically determines the unit of the result channels.

<http://eco-region31.ru/bosch-nexxt-essence-washer-manual>